

Item Code: ES-GS945/CMH

Description: 945W DE CMH GROWING SYSTEM 240V

Performance

Lamp	Number	1
	Watts	945W
Input Volts		240V
Input Current		4.23A
Input Power		1000W
Min Power Factor		0.95
THD		<15%
Crest Factor		<1.7

Protections

1. End of Lamp Life (EOL) Protection.
2. Short circuit protection.
3. Open circuit protection.
4. Ignition failure protection.
5. Thermal protection.

Installation & Application Notes

1. Max. allowable case temperature: 75°C/167°F.
2. Ambient Temperature: -20 ~ +40°C/-4 ~ +104°F.
3. Max. Humidity: 95%.
4. Ignition voltage is 5kV.

Physical

Case Length	244.5mm	9.75"
Case Width	174.5mm	7.00"
Height	107.5mm	4.25"
Weight	5.8kg	13lbs

Performance Requirements

Rated mains voltage:	240V
Voltage range (+/-10%):	216-264V
Mains frequency:	50/60Hz
Operation frequency	140-220Hz

Dimming Type

Gear	825	1000
------	-----	------

Main Dimension

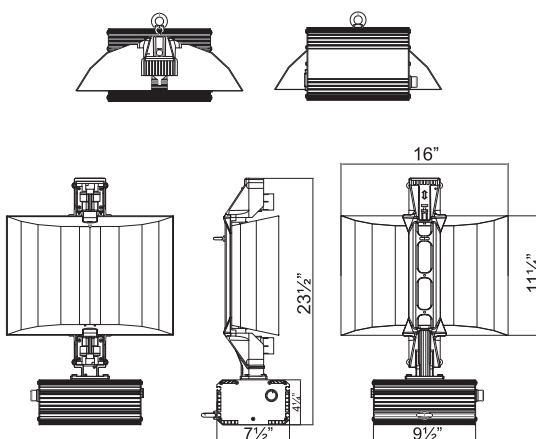

Wiring Diagram

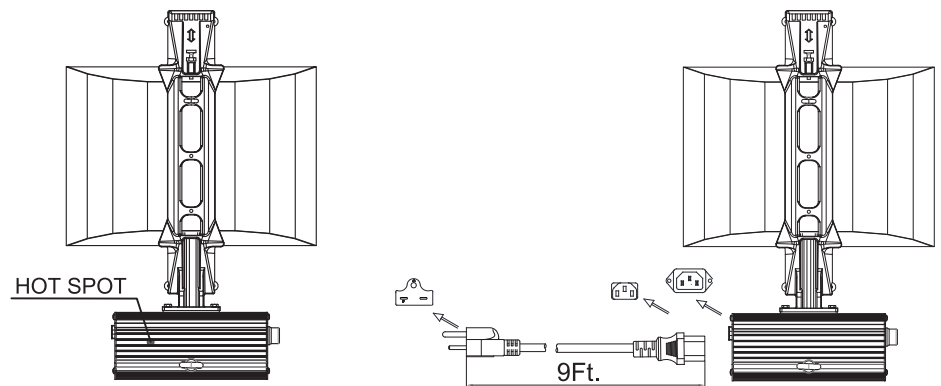

Tcase max=75°C/167°F

Ballast case must be grounded